

TA40.T

TESTA AD ANGOLO - ANGLE HEAD

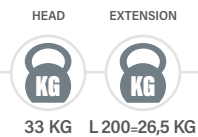

PESO
WEIGHT

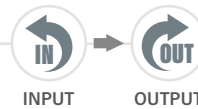

ROTAZIONE
ROTATION

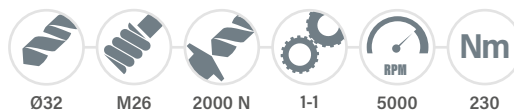

CARATTERISTICHE
FEATURES



MANDRINI
DISPONIBILI
AVAILABLE
SPINDLES

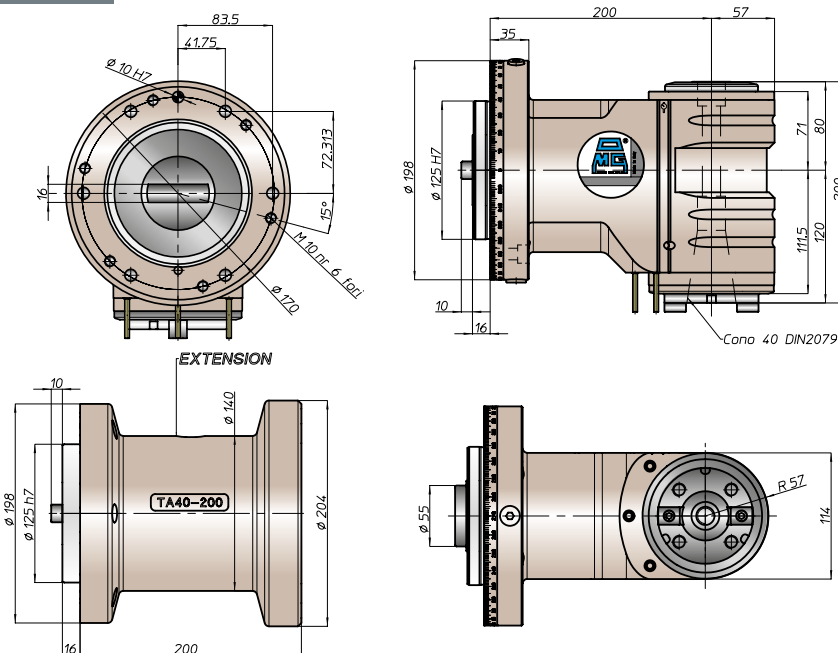

Equipaggiamento standard:

- pressurizzazione mandrino
- n. 3 ugelli orientabili vicino al mandrino
- nel mandrino DIN2079 si possono utilizzare coni DIN2080-40, DIN69871-A40, MAS403-BT40

Standard equipment:

- spindle front pressurization
- nr. 3 adjustable nozzle near the spindle
- on the spindle DIN2079 you can use shank DIN2080-40, DIN69871-A40, MAS403-BT40

Utilizzo su asse C manuale / Manual C axis

- Nuovo Asse C a rotazione manuale
- Compatto, semplice e preciso
- Bloccaggio rotazione su cava a T
- Rotazione libera su cuscinetto a rulli incrociati
- Facilità di posizionamento
- New C Axis with manual rotation
- Space-saving, user friendly and precise
- Rotation lock on T slot
- Free rotation on crossed roller bearings
- Easy set up

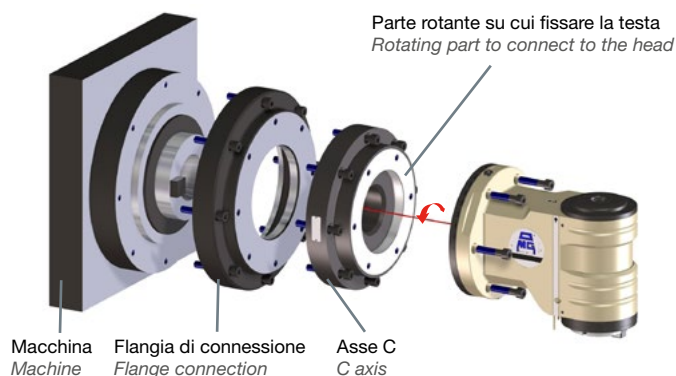

Macchina
Machine

Flangia di connessione
Flange connection

Asse C
C axis

Parte rotante su cui fissare la testa
Rotating part to connect to the head

