

PESO  
WEIGHT

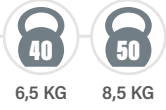

ROTAZIONE  
ROTATION

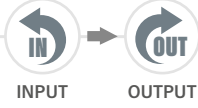

CARATTERISTICHE  
FEATURES

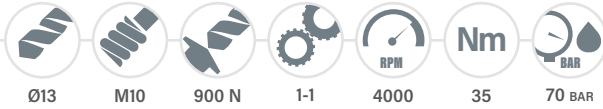

MANDRINI  
DISPONIBILI  
AVAILABLE  
SPINDLES

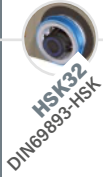

# TAFE13.PD

TESTA AD ANGOLO - ANGLE HEAD

FH

BAH

TA.CP

TA

MOX

HT

4-98

VH

TSI/TSX

T

MT-TC-TC3

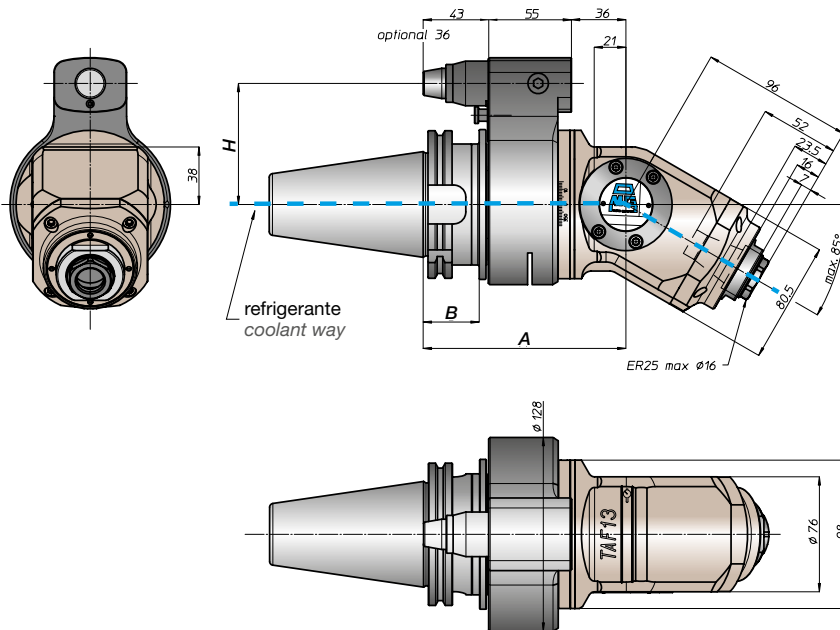

CONO  
SHANK

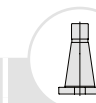
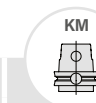
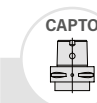

SIZE

40 45 50 40 50 40 50 63 80 100 C5 C6 C8 63 80 100

A

134 134 134 142 143 138 134

B

35 35 35 45 44 46 39 41

H STANDARD

65 80 65 80 65 80 65 80 65 80

H OPTIONAL

110 110 110 110 110 110 110

