

PESO
WEIGHT

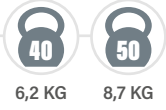

ROTAZIONE
ROTATION

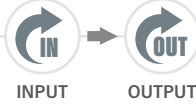

CARATTERISTICHE
FEATURES

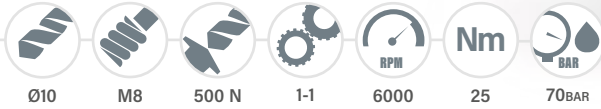

MANDRINI
DISPONIBILI
AVAILABLE
SPINDLES



TAO10.PD

TESTA AD ANGOLO - ANGLE HEAD

FH

BAH

TA.CP

TA

MOX

HT

4-66

VH

TSI/TSX

T

MT-TC-TC3

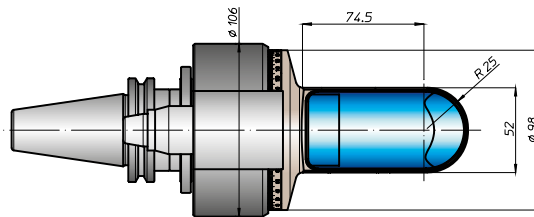
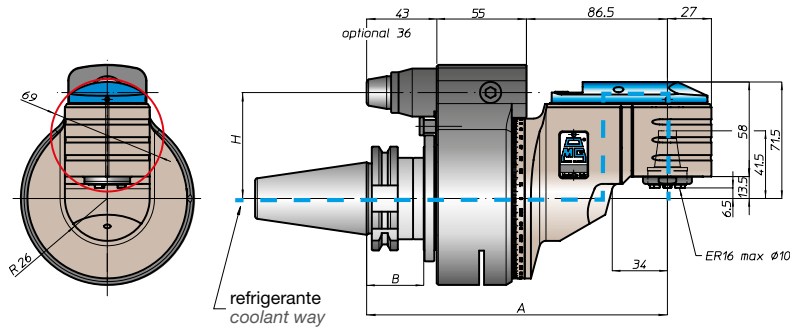

CONO
SHANK

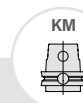
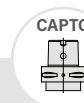

SIZE

40 45 50 40 50 40 50 63 80 100 C5 C6 C8 63 80 100

A

184,5 184,5 184,5 192,5 193,5 188,5 184,5

B

35 35 35 45 44 46 39 41

H STANDARD

65 80 65 80 65 80 65 80 65 80 65 80

H OPTIONAL

110 110 110 110 110 110 110

For DIN69871, ANSIB5.50 and BT, dual contact as option

