

TA013.PD

TESTA AD ANGOLO - ANGLE HEAD

FH

BAH

TA.CP

TA

MOX

HT

4-68

VH

TSI/TSX

T

MT-TC-TC3



PESO
WEIGHT



ROTAZIONE
ROTATION

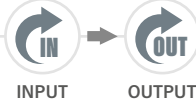

CARATTERISTICHE
FEATURES

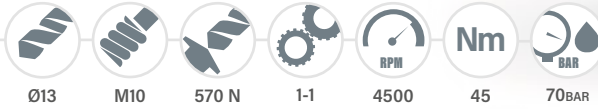

MANDRINI
DISPONIBILI
AVAILABLE
SPINDLES

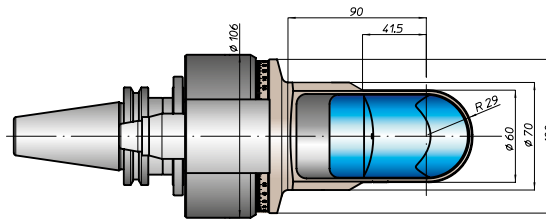
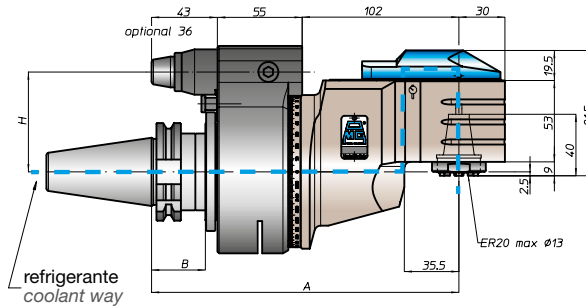
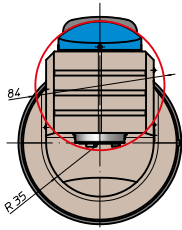
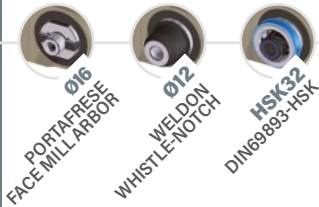

CONO
SHANK



DIN69871



ANSIB5.50



DIN69893

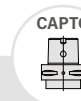

ISO26623

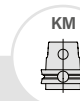

DIN2080



ANSIB5.18

SIZE

	40	45	50	40	50	40	50	63	80	100	C5	C6	C8	63	80	100		
--	----	----	----	----	----	----	----	----	----	-----	----	----	----	----	----	-----	--	--

A

	200			200		200		208		209		204		200			
--	-----	--	--	-----	--	-----	--	-----	--	-----	--	-----	--	-----	--	--	--

B

	35			35		35		45		44		46		39		41			
--	----	--	--	----	--	----	--	----	--	----	--	----	--	----	--	----	--	--	--

H STANDARD

	65	80	65	80	65	80	65	80	65	80	65	80	65	80	65	80		
--	----	----	----	----	----	----	----	----	----	----	----	----	----	----	----	----	--	--

H OPTIONAL

	110			110		110		110		110		110		110			
--	-----	--	--	-----	--	-----	--	-----	--	-----	--	-----	--	-----	--	--	--

For DIN69871, ANSIB5.50 and BT, dual contact as option