

PESO  
WEIGHT

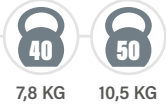

ROTAZIONE  
ROTATION

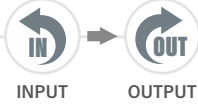

CARATTERISTICHE  
FEATURES

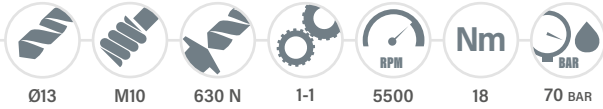

MANDRINI  
DISPONIBILI  
AVAILABLE  
SPINDLES



# TAV13.PD

TESTA AD ANGOLO - ANGLE HEAD

FH

BAH

TA.CP

TA

MOX

HT

4-88

VH

TSI/TSX

T

MT-TC-TC3

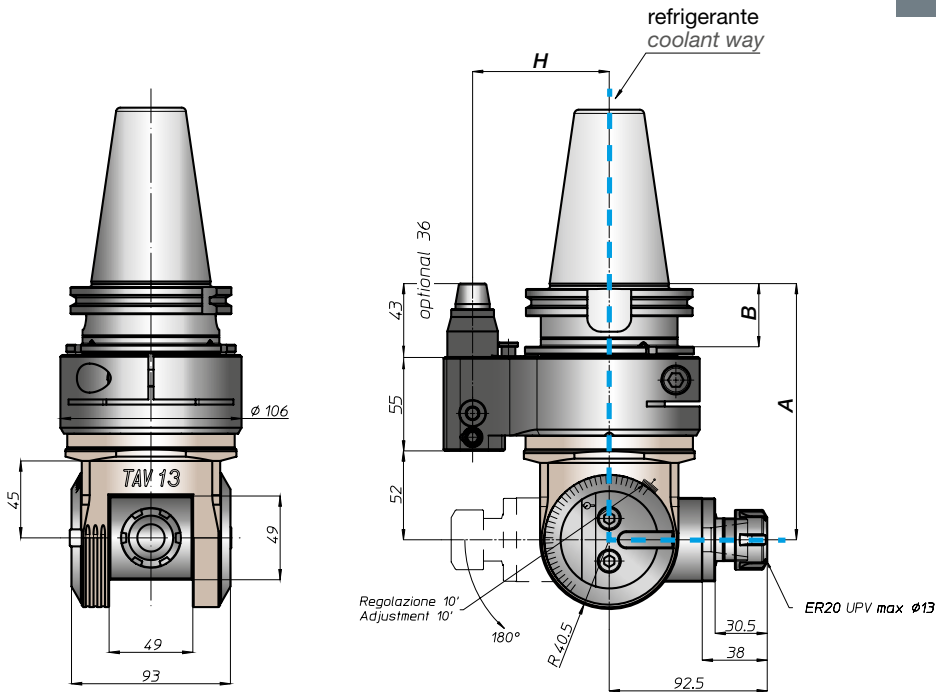

CONO  
SHANK

SIZE

A

B

H STANDARD

H OPTIONAL



DIN69871



ANSIB5.50



DIN69893

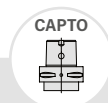

ISO26623

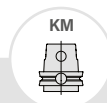

DIN2080



ANSIB5.18

	DIN69871			ANSIB5.50		BT		DIN69893			ISO26623			DIN2080		ANSIB5.18		
SIZE	40	45	50	40	50	40	50	63	80	100	C5	C6	C8	63	80	100	40	
A	150			150		150	158	159			154			150		120		
B	35			35		35	45	44	46		39	41			13			
H STANDARD	65	80		65	80	65	80	65	80		65	80	65	80	65			
H OPTIONAL	110			110		110			110			110			110			

For DIN69871, ANSIB5.50 and BT, dual contact as option

