



TAV40.T

TESTA AD ANGOLO - ANGLE HEAD



TAV
DIGITAL



PESO
WEIGHT

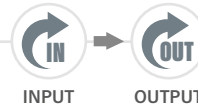

ROTAZIONE
ROTATION

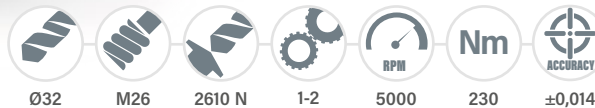

CARATTERISTICHE
FEATURES



MANDRINI
DISPONIBILI
AVAILABLE
SPINDLES

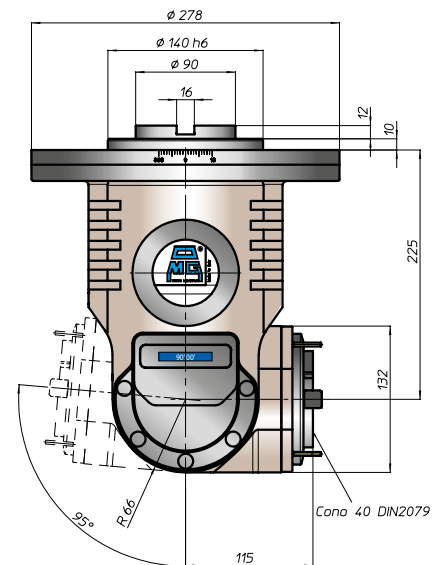
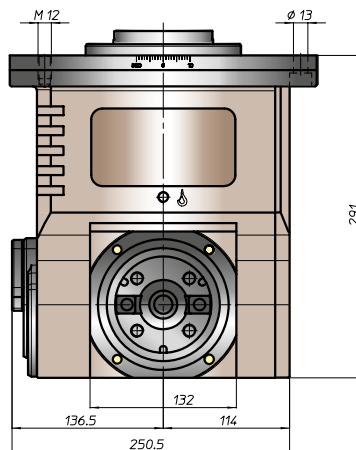
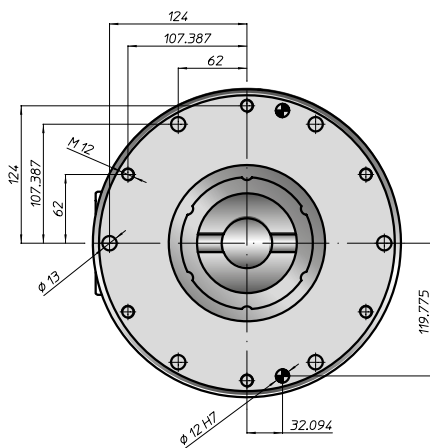

Esempio di collegamento / Connection example

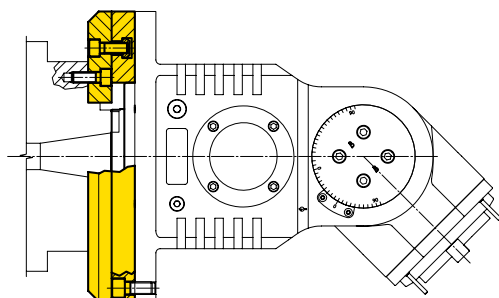

Equipaggiamento standard:

- pressurizzazione mandrino
- n. 4 ugelli orientabili vicino al mandrino
- regolazione angolare mandrino libera
- nel mandrino DIN2079 si possono utilizzare coni DIN2080-40, DIN69871-A40, MAS403-BT40

Standard equipment:

- spindle front pressurization
- nr. 4 adjustable nozzle near the spindle
- free angle spindle adjustment
- on the spindle DIN2079 you can use shank DIN2080-40, DIN69871-A40, MAS403-BT40