

PESO
WEIGHT

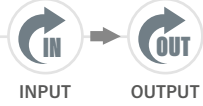

145 KG

ROTAZIONE
ROTATION



INPUT OUTPUT

CARATTERISTICHE
FEATURES

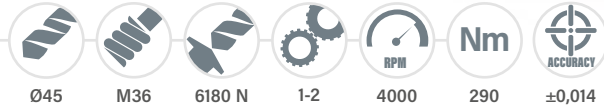

Ø45 M36 6180 N 1-2 4000 290 ±0,014

MANDRINI
DISPONIBILI
AVAILABLE
SPINDLES



HSKA100
DIN69893-HSK

C8
COROMANT CAPTO®

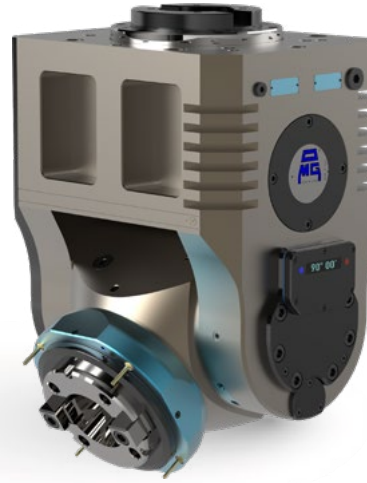

TAV50.T

TESTA AD ANGOLO - ANGLE HEAD

FH

BAH

TA.CP

TA

MOX

HT

4-84

VH

TSI/TSX

T

MT-TC-TC3

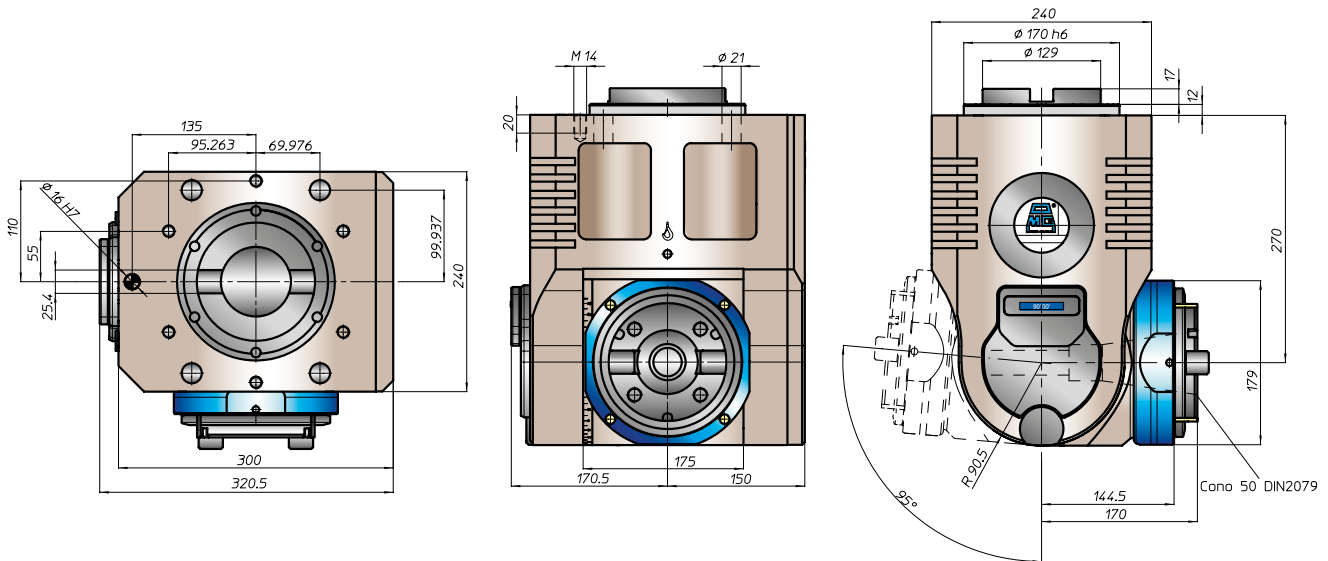

Esempio di collegamento / Connection example

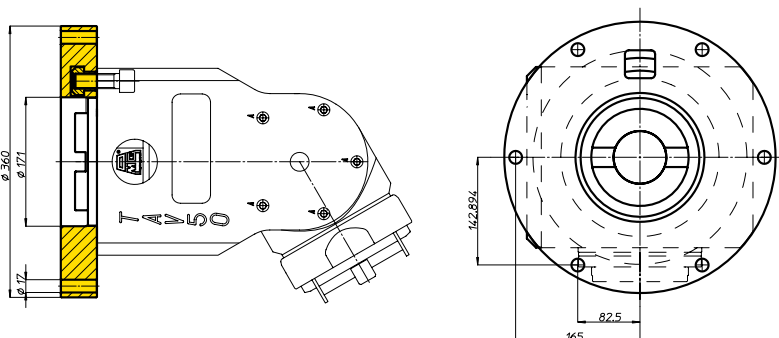

Equipaggiamento standard:

- pressurizzazione mandrino
- n. 4 ugelli orientabili vicino al mandrino
- regolazione angolare mandrino libera o posizionabile ogni 15°
- nel mandrino DIN2079 si possono utilizzare coni DIN69871-A50, MAS403-BT50

Standard equipment:

- spindle front pressurization
- nr. 4 adjustable nozzle near the spindle
- free angle spindle adjustment or by pin each 15°
- on the spindle DIN2079 you can use shank DIN69871-A50, MAS403-BT50