



VH06

TESTE MULTIPLE AD ASSI VARIABILI - VARIABLE AXIS HEADS



CAPACITÀ FORATURA
DRILLING CAPACITY

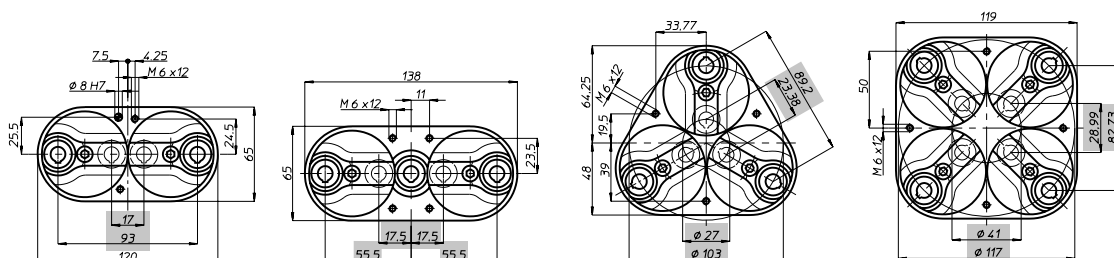
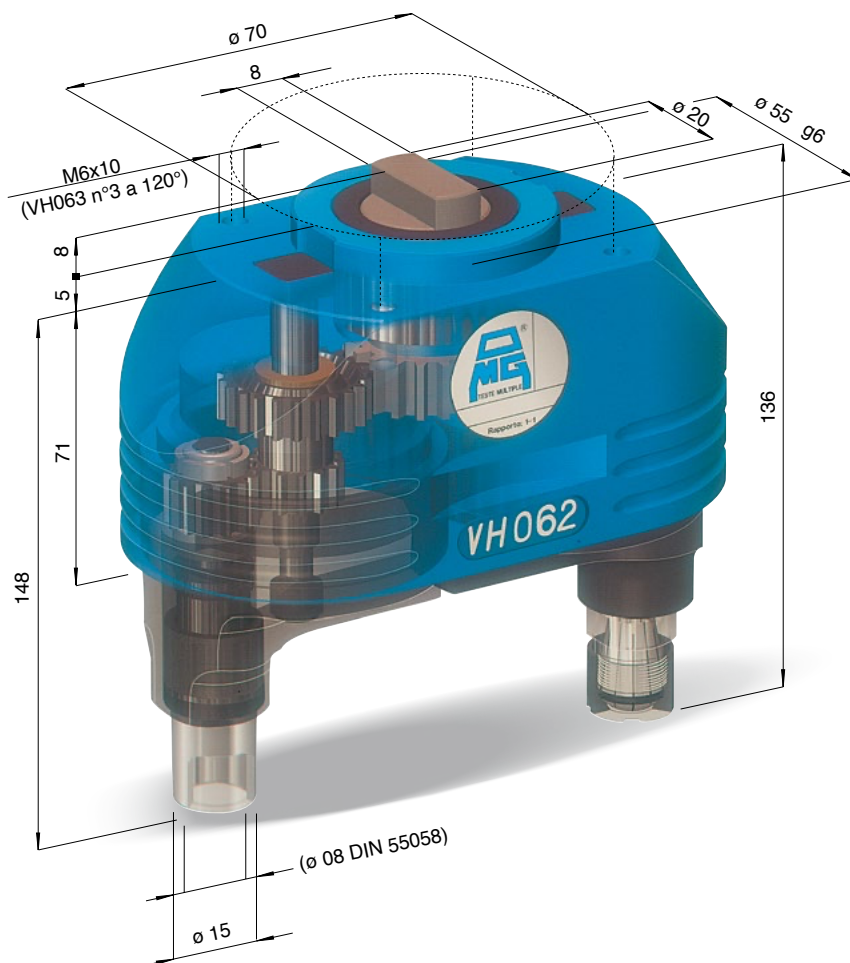

TESTA MODELLO
HEAD TYPE

VH 062

VH 063 L

VH 063

VH 064

ARTICOLO
ITEM

VH 062 P

VH 063 LP

VH 063 P

VH 064 P

ATTACCO UTENSILE
SPINDLE TYPE

ER 11 - max $\phi 7$

ARTICOLO
ITEM

VH 062 D

VH 063 LD

VH 063 D

VH 064 D

ATTACCO UTENSILE
SPINDLE TYPE

DIN55058 - $\phi 8$

N. MANDRINI
SPINDLES NR.

2

3

3

4

CAMPO DI LAVORO MIN.
CENTRE DISTANCES MIN.

17

17,5 + 17,5

$\phi 27$

$\phi 41$

CAMPO DI LAVORO MAX.
CENTRE DISTANCES MAX.

93

55,5 + 55,5

$\phi 103$

$\phi 117$

CAPACITÀ FORATURA
DRILLING CAPACITY

ACCIAIO/STILL Rm 500 N/mm² - $\phi 6$ | GHISA/CAST IRON GG25 - $\phi 7$

MASCHIATURA
TAPPING

M 5

RAPPORTO
RATIO

1 - 1

VELOCITÀ
RPM

4.000

PESO
WEIGHT

1,65 kg

1,95 kg

2,3 kg

3,1 kg

