



VH13

TESTE MULTIPLE AD ASSI VARIABILI - VARIABLE AXIS HEADS

014

CAPACITÀ FORATURA
DRILLING CAPACITY

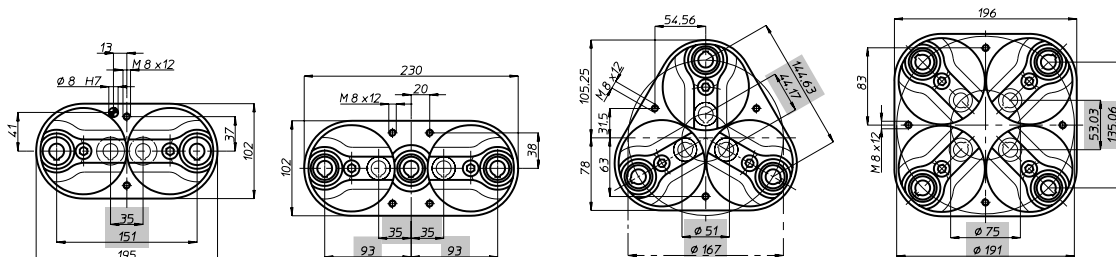
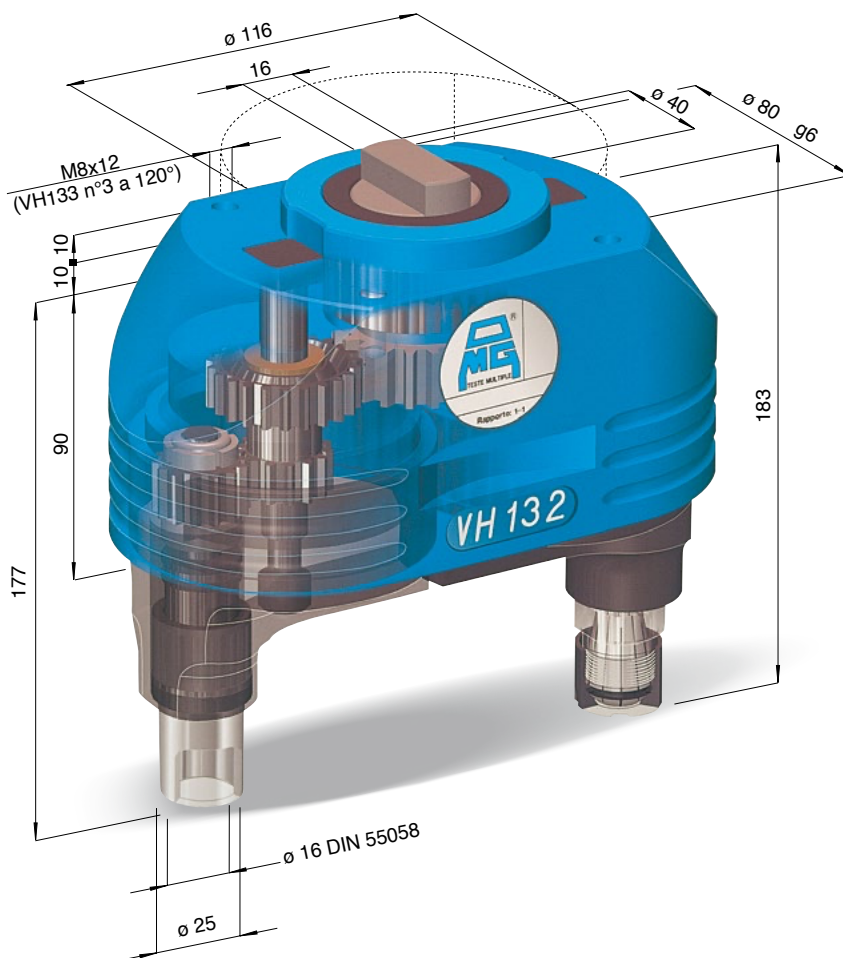

TESTA MODELLO
HEAD TYPE

VH 132

VH 133 L

VH 133

VH 134

ARTICOLO
ITEM

VH 132 P

VH 133 LP

VH 133 P

VH 134 P

ATTACCO UTENSILE
SPINDLE TYPE

ER 20 - max \varnothing 13

ARTICOLO
ITEM

VH 132 D

VH 133 LD

VH 133 D

VH 134 D

ATTACCO UTENSILE
SPINDLE TYPE

DIN55058 - \varnothing 16

N. MANDRINI
SPINDLES NR.

2

3

3

4

CAMPO DI LAVORO MIN.
CENTRE DISTANCES MIN.

35

35 + 35

\varnothing 51

\varnothing 75

CAMPO DI LAVORO MAX.
CENTRE DISTANCES MAX.

151

93 + 93

\varnothing 167

\varnothing 191

CAPACITÀ FORATURA
DRILLING CAPACITY

ACCIAIO/STILL Rm 500 N/mm² - \varnothing 13 | GHISA/CAST IRON GG25 - \varnothing 14

MASCHIATURA
TAPPING

M 12

RAPPORTO
RATIO

1 - 1

VELOCITÀ
RPM

3.000

PESO
WEIGHT

5,3 kg

7,2 kg

7 kg

10,8 kg

