

NOTA:
NOTE:

A.B.C.D. DATI MACCHINA
A.B.C.D. MACHINE FEATURES

VH13

MANICOTTO DI COLLEGAMENTO - CONNECTION COLLAR

DIN 238	CODICE
B 16	011279
B 18	011280
B 22	011281
B 24	011282

DIN 55058	CODICE
16	525405
20	525406
28	525407
36	525408

DIN 228	CODICE
cm 2	011120
cm 3	011125
cm 4	011130
cm 5	011135

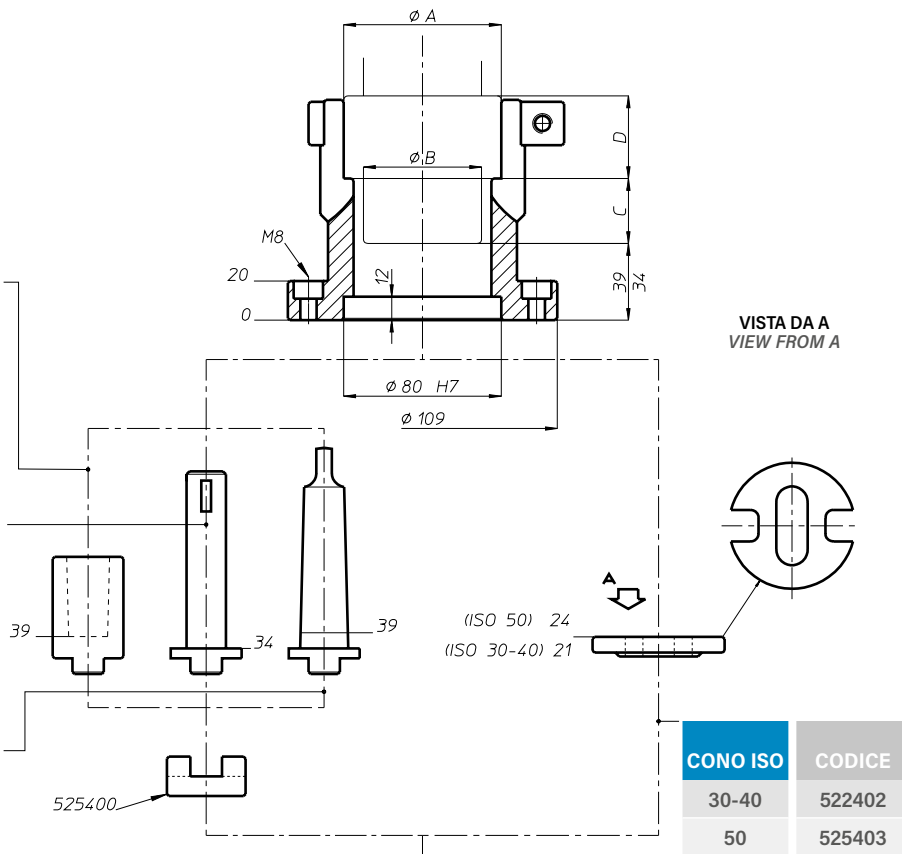

Nota:

L'utilizzo di questo accessorio richiede il mandrino preposto. La lunghezza degli accessori, comprensivi di manicotto attaccorapido, aumenta di mm 9,5.

Note:

The use of this accessory requires prearranged spindle. The length of this accessories whit quick connection sleeve increases of mm 9,5.

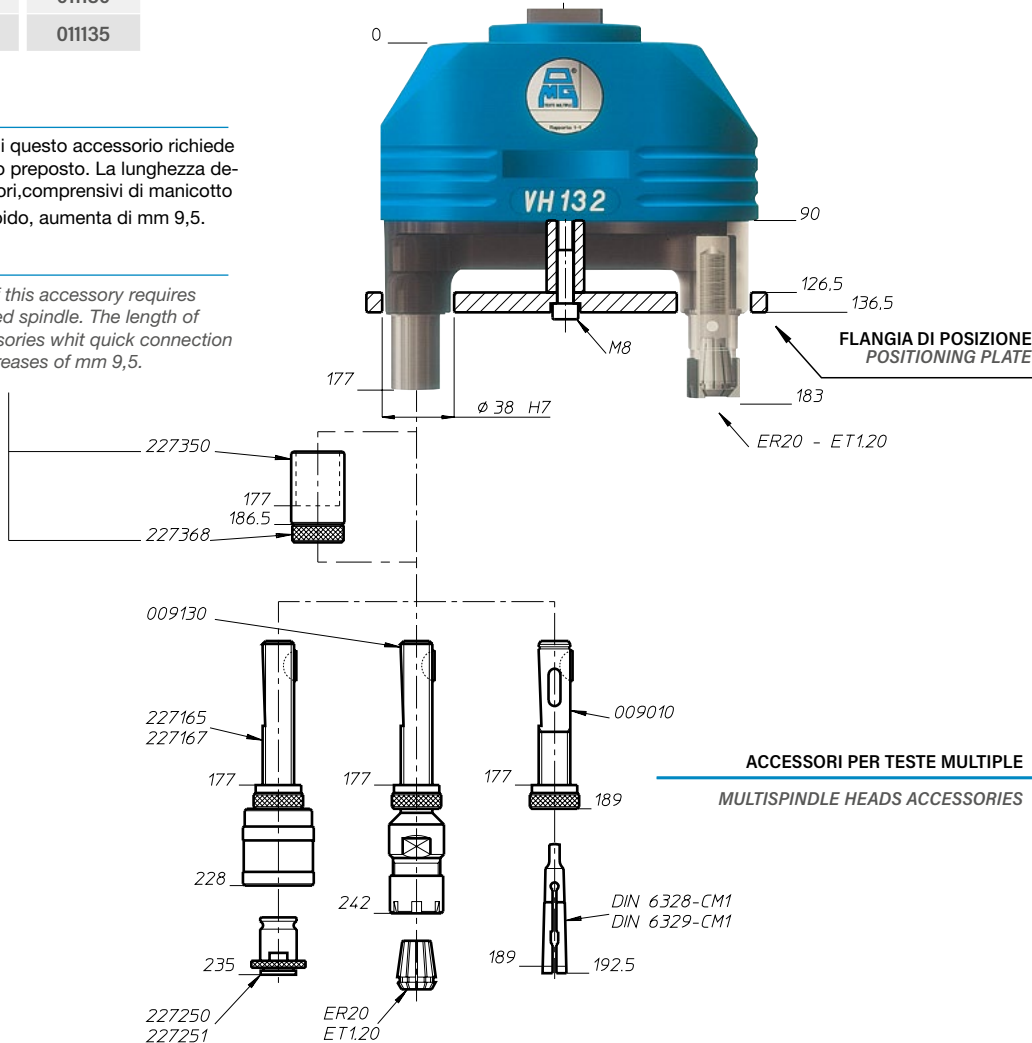

FH

BAH

TA.CP

TA

MOX

HT

7-12

VH

TSI/TSX

T

MT-TC-TC3

