

NOTA:  
NOTE:

A.B.C.D. DATI MACCHINA

A.B.C.D. MACHINE FEATURES

# VH25

MANICOTTO DI COLLEGAMENTO · CONNECTION COLLAR

DIN 238	CODICE
B 18	011280
B 22	011281
B 24	011282

DIN 55058	CODICE
16	525405
20	525406
28	525407
36	525408

DIN 228	CODICE
cm 3	011125
cm 4	011130
cm 5	011135

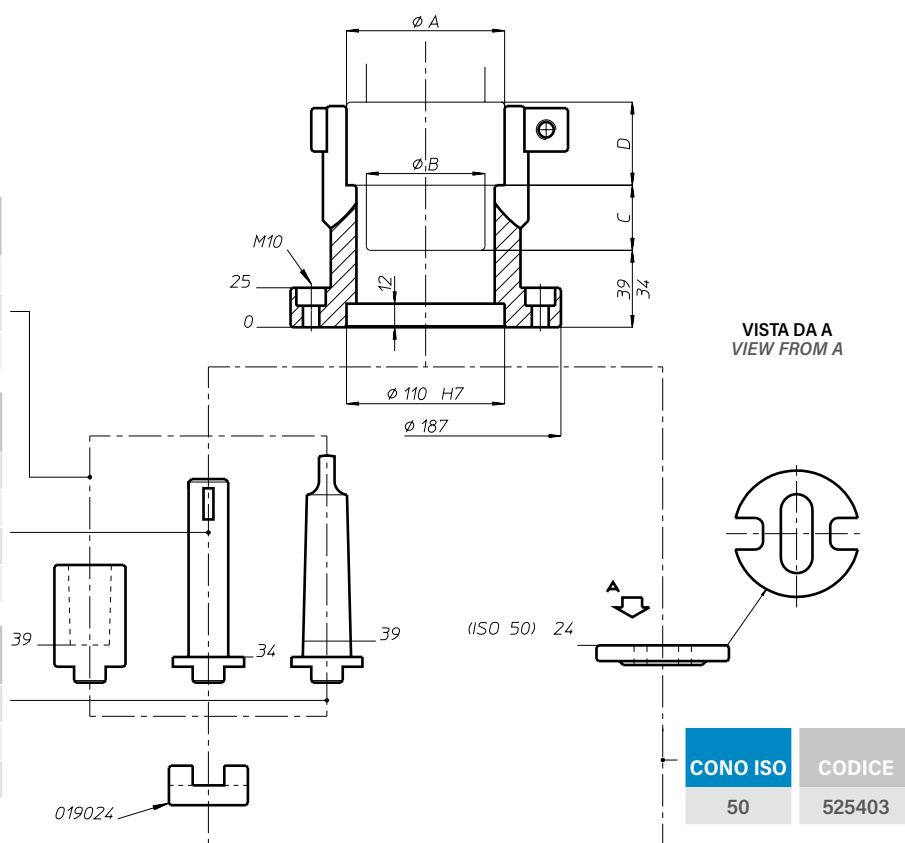

**Nota:**

L'utilizzo di questo accessorio richiede il mandrino preposto. La lunghezza degli accessori, comprensivi di manicotto attacco Rapido, aumenta di mm 9,5.

**Note:**

The use of this accessory requires prearranged spindle. The length of this accessories whit quick connection sleeve increases of mm 9,5.

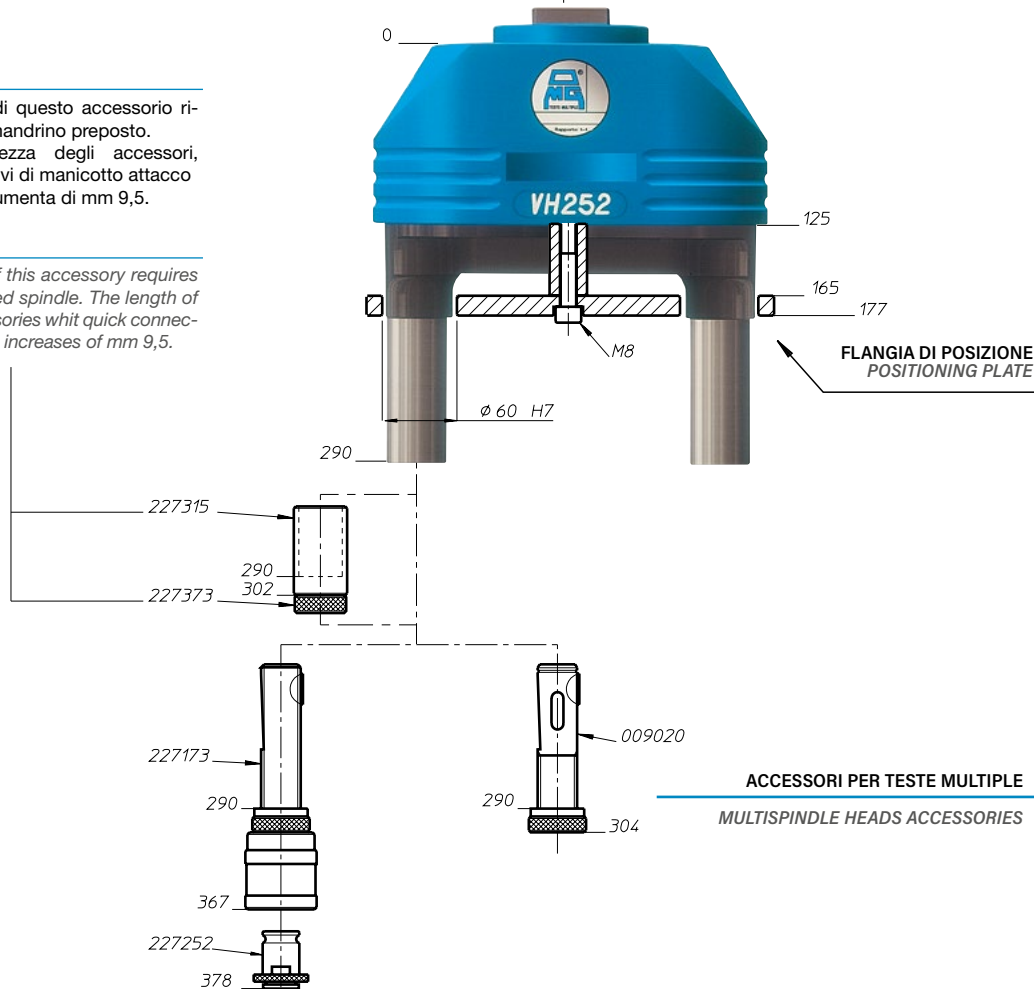

ACCESSORI PER TESTE MULTIPLE  
MULTISPINDLE HEADS ACCESSORIES

FH  
BAH  
TA.CP  
TA  
MOX  
HT  
7-16

VH

TSI/TSX

T

MT-TC-TC3

